

BASCO® ENGINEERED

SHELL & TUBE HEAT EXCHANGERS



Meet Our Team

API Heat Transfer is your one source for custom-engineered shell & tube heat exchangers, offering sizes from 2" to 115" in diameter and lengths up to 50 feet. API Basco is a full-service manufacturer that combines our human talent with our state-of-the-art manufacturing facility and our applications expertise with our mechanical design know-how. Committed to excellence, we are driven to deliver outstanding service and value to our customers -- every time.

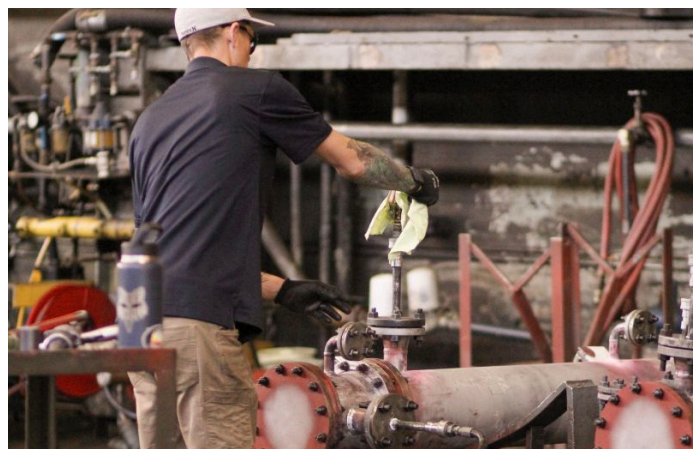
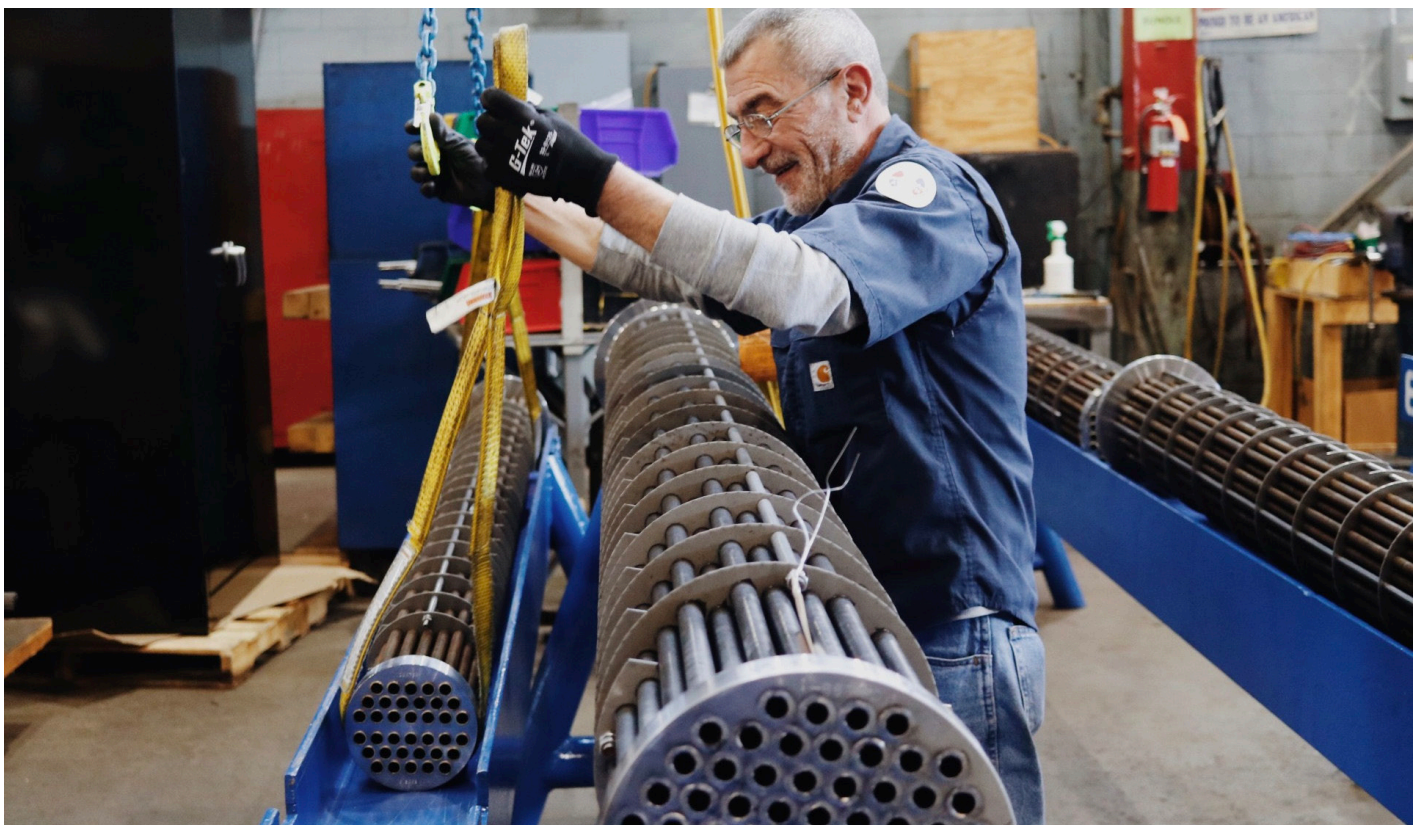

Manufacturing

Our 80,000 sq. ft. manufacturing space is ISO 9001 certified and houses extensive fabrication resources including various CNC drilling and machining centers, turning centers, and CNC punch presses. We utilize multiple bridge and jib cranes, a multi-media blast facility, burning table, tube-bending equipment, and a vast array of other support equipment to manufacture high-quality, custom shell & tube heat exchangers. Our manufacturing skill set encompasses a broad spectrum of expertise, ranging from precision torque control rolling to meticulous seal and strength welding techniques. With expertise in a variety of welding methods including TIG, MIG, GMAW, GTAW, SAW, and SMAW, we demonstrate a versatile understanding of welding processes tailored to diverse manufacturing needs. Additionally, our adeptness in polishing techniques underscores our commitment to achieving impeccable surface finishes. Moreover, our mastery in adhering to Tubular Exchanger Manufacturers Association (TEMA) standards for achieving tight drilling tolerances highlights our dedication to precision engineering and quality assurance within manufacturing operations.

Quality Assurance

Each stage of manufacturing is subjected to rigorous inspection and testing scrutiny – from incoming material to completed assembly. A resident ASME-authorized inspector oversees the complete manufacturing operation. Our in-house quality team ensures that the proper procedures are in place, that our employees are well trained, and that all the required inspections occur at the critical stages of assembly. Basco is well versed in all major pressure vessel codes, invests regularly in maintaining our various code certifications and can offer a wide range of testing, typical within the shell & tube industry.

Product Development

API Heat Transfer invests continuously to stay at the forefront of technology. Our product development staff and on-site test facility distinguishes API Heat Transfer from many of our peers. We believe a strong focus on new products adds real value for our customers. By working closely with our

customers during their new product development or product redesign cycle, API Heat Transfer can provide a solution that optimizes thermal efficiency, pressure loss, size, weight, and price to provide the best overall value. Our involvement in product development spans across various critical stages, from performance and fatigue testing to thermal-cycling evaluations. Additionally, we lead prototype development efforts and contribute to thermal software development, ensuring the robustness and reliability of products across diverse environmental conditions.

Applications Engineering

Our highly knowledgeable and experienced staff of application engineers use state-of-the-art software technology including HYSIM, B-JAC and HTRI as well as proprietary rating systems developed in-house. Combining Basco's engineering know-how with sophisticated software tools ensures the best solution for each application. Heat loads, pressure drop restrictions, phase change, materials of construction, numerous international code requirements, and customer specifications are only some of the criteria our engineers assess on every project. After thorough review of all the parameters, a complete professional proposal is generated for the appropriate Basco/Whitlock Shell & Tube design.

Mechanical Engineering

Basco employs a full mechanical design team to handle all contract work. We are well versed in ASME codes as well as other regional pressure-vessel regulations. Our designers ensure the accuracy of drawings using the latest 2-D and 3-D modeling software. Developing accurate bills of material, producing all necessary code calculations, and ensuring proper completion of all required code paperwork and inspection reports are all part of the daily activities for this team of design professionals.

API Machines

MCR Double Column Machine

Similar to a horizontal bridge mill, the MCR Double Column Machine delivers a new era of precision machining. With its 5-face machining capability and a RAM 90-degree spindle head designed for horizontal milling, this machine delivers unparalleled performance for complex machining tasks

- Travel Dimensions: 186”L x 73”W x 60”H, accommodating a tool length of 5”
- Travel Speed: Achieving up to 30 m/s
- Point-to-point measurement within .001”
- Allows for machining of very large parts on every axis without tooling changes
- Can handle smaller parts in mass quantities
- Allows for removal of skirts on some of the equipment in the ES product line



MCR Double Column Machine

Annihilator

The Annihilator is best described as power meets precision in a compact design. This small-footprint gantry mill boasts a 30HP main drive and spindle speeds of up to 8,000 rpm. Offering extensive travel capabilities, it ensures exceptional machining results across a range of applications with accompanying chip conveyors to reduce cleanup times. Plus, it allows for vertical milling 32x faster than its predecessor

- Travel Dimensions: X Axis: 96” – 824”, Y Axis: 36” – 200”, Z Axis: 26”



Annihilator

Plasma/Oxy Cutter

Our Plasma/Oxy Cutter offers unparalleled versatility, catering to a wide range of cutting requirements. With cutting widths from 6’ to 12’ and cutting lengths spanning from 10’ to 100’, it ensures precise results across various materials. Equipped with water or downdraft table options and featuring a table capacity of 8”, along with plasma systems ranging from 45 to 400 amps, it is tailored to meet the diverse needs of modern machining operations. It can plasma cut plate up to 4”, streamlining most base components for shell & tube heat exchangers (flanges, tubesheets, bonnets, etc). Additional features include a full-contour plasma bevel and an oxy-fuel and marking station, providing additional flexibility for customized machining tasks.



Plasma/Oxy Cutter

Multus Okuma

Maximizing efficiency with seamless integration, the Multus Okuma sets a new standard for efficiency. It features 2 chucks and an adaptive 6-axis head that empowers users to chamfer, drill, tap, and mill—all within a single machine. Ideal for parts measuring 12” and under, it has significantly streamlined commercial lead times, enhancing productivity and performance.

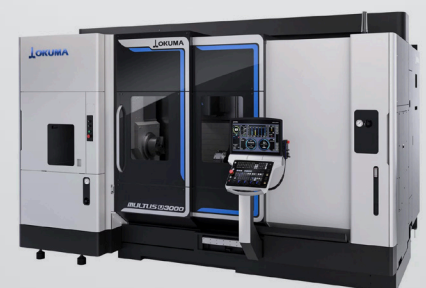

Multus Okuma

Gasket Cutter

Our Gasket Cutter provides instant solutions for aftermarket needs to meet the urgent demands of aftermarket customers. With rapid setup and operation, it delivers precise gaskets on the same day to supply MRO activities as well as service so we can offer same-day shipping to our aftermarket customers. We cater to diverse materials such as Teadit NA1001, SBR + silicon.

Trupunch 1000

This advanced-sheet metal-punching machine offers unparalleled performance, delivering precise results across a range of materials including steel and aluminum. With high-speed punching capabilities and rapid tool changing, the Trupunch 1000 maximizes productivity without sacrificing quality. It allows for streamlined mass production of baffles for our commercial standard coolers, reducing end-to-end lead time for all shell & tube heat exchangers. TruPunch 1000 combines robust construction with minimal maintenance requirements, whether you're producing prototypes or high-volume runs

Amada Saw (VT 5063s)

The Amada Vertical Band Saw: where precision and efficiency come together for superior metal cutting. With adjustable configurations and high-speed performance, it ensures accurate cuts across various materials. Its user-friendly interface and robust construction make it ideal for diverse industrial settings. This has increased cutting accuracy within the shop to reduce rework on shell pipe as well as nozzles and flanges. This saw features +/- 30 degrees of travel, allowing for angle cuts.

Other Machines

The manufacturing facility is equipped with CNC drilling, machining, and turning centers, along with a punch press and burning table for metal fabrication. Additionally, it features heavy-duty bridge cranes, a tube bender, multi-media blast facility, high-capacity air dryer, and a plate-fin press for diverse production needs.



Gasket Cutter



Trupunch 1000



Amada Saw

Engineering Capabilities

In-House Resources

- Accredited Staff Engineer
- Specialized Application Proficiency
- Advanced Mechanical Design Competence
- Holistic Product Development
- Reverse Engineering Capabilities

Markets Served

- Air Separation
- Alternate Energy
- Chemical
- Compressor
- Data Center Cooling
- Electronics
- Fluid Power
- Hydrogen Production
- Industrial
- Marine
- Nuclear
- Oil & Gas
- Pharmaceutical
- Plastics
- Power Generation
- Pulp & Paper
- Refrigeration

Core Capabilities

- ASME Section VIII Division 1
- PED
- TEMA C, B & R
- Canadian Registration
- Australian AS-1210
- Polish UDT

Software

- HTRI
- B-JAC
- FEA
- 3-D Modeling
- CFD – Computational Fluid Dynamics
- HYSIM Process Modeling
- In-house Engineering Software Development

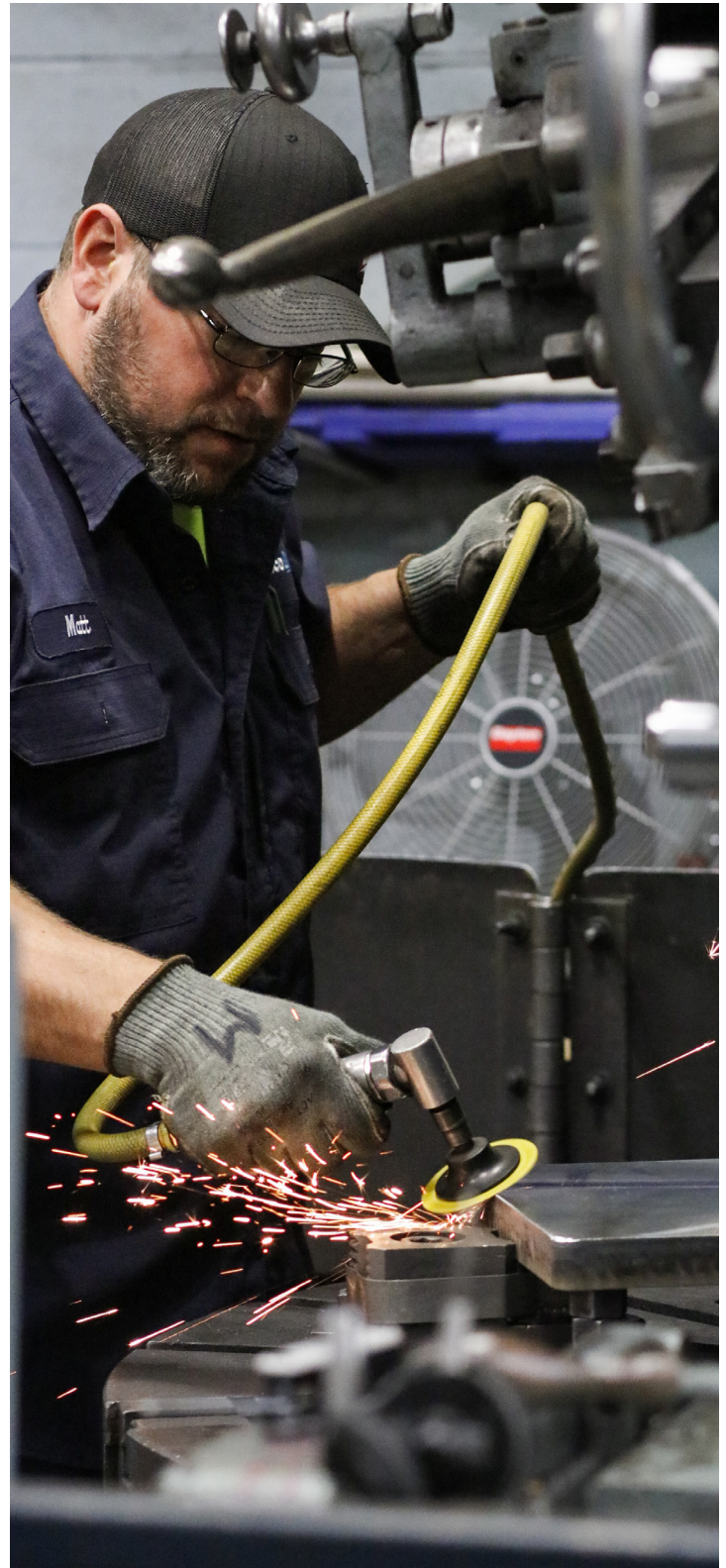

TEMA Shell & Tube Solutions

API Basco is an experienced supplier of TEMA heat exchangers. TEMA (Tubular Exchanger Manufacturers Association) sets the standards by which virtually all custom shell & tube heat exchangers are specified and built. API Basco has been designing TEMA units since the 1950s, and consequently, we have a complete and comprehensive understanding of the engineering, manufacturing, and testing requirements to meet this world-recognized standard.

	FRONT END STATIONARY HEAD TYPES	SHELL TYPES	REAR END HEAD TYPES
A	 CHANNEL AND REMOVABLE COVER	E ONE PASS SHELL	L FIXED TUBESHEET LIKE "A" STATIONARY HEAD
B	 BONNET (INTEGRAL COVER)	F TWO PASS SHELL WITH LONGITUDINAL BAFFLE	M FIXED TUBESHEET LIKE "B" STATIONARY HEAD
C	 REMOVABLE TUBE BUNDLE ONLY CHANNEL INTEGRAL WITH TUBE-SHEET AND REMOVABLE COVER	G SPLIT FLOW	N FIXED TUBESHEET LIKE "N" STATIONARY HEAD
N	 CHANNEL INTEGRAL WITH TUBE-SHEET AND REMOVABLE COVER	H DOUBLE SPLIT FLOW	P OUTSIDE PACKED FLOATING HEAD
D	 SPECIAL HIGH PRESSURE CLOSURE	J DIVIDED FLOW	S FLOATING HEAD WITH BACKING DEVICE
		K KETTLE TYPE REBOILER	T PULL THROUGH FLOATING HEAD
		X CROSS FLOW	U U-TUBE BUNDLE
			W EXTERNALLY SEALED FLOATING TUBESHEET



TYPE ES Intercoolers on a Compressor Package



High Pressure TEMA BEP (Oxygen Cleaned)



TEMA AEL

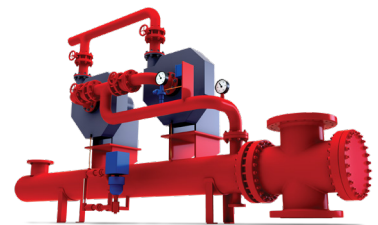

Gland Condenser Package

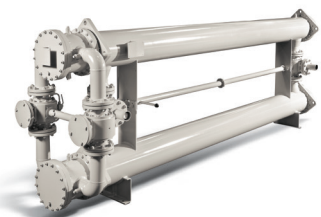

Stacked TEMA AEW with Transfer Values



Custom-Engineered Falling Film Ammonium Nitrate Evaporator



TEMA Bundle Assembly Bay



Dual-Circuit ES Cooler Bundle Insertion



Full-Size ES Unit (55') for Compressor Package

TEMA Shell & Tube Specifications

TEMA BET Type 1

Description: Pull-through tube bundle studded internal floating head to tubesheet joint multi-pass tubeside or single pass with Slip Tube design channel or bonnet tubeside connection pressure range – 75 psi to 300 psi.

Applications: Liquid heaters with low-pressure steam on the shell side single and double shell (gas in shell) compressor intercoolers on refinery applications shellside gas or oil coolers.

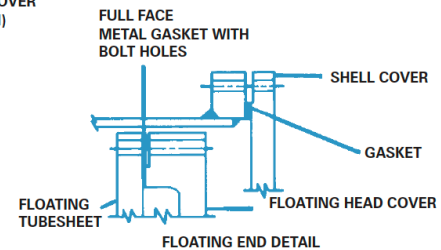
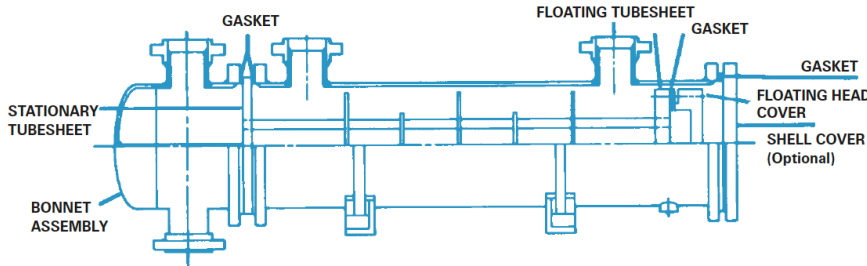

Advantages:

Relatively large annulus around outer tube limit (OTL) and shell ID permits entrance to the tube bundle with little resistance. The results are low entrance-exit velocities and pressure loss. Easily removable tube bundle. Tube bundle expands freely with no special provisions for expansion.

Limitations:

1. No gasket leak detection at floating head and tubesheet.
2. Relatively low thermal efficiency due to large annulus between outer tube limit (OTL) and shell ID (results in low shell side heat transfer coefficient).
3. Fewer tubes for any given shell size compared to other types.

TEMA AES Type 2

Description: Removable tube bundle, split clamp-ring floating head multi-pass tubeside or single pass with Slip Tube design floating head bolted to split clamp-ring (requires shell cover larger than shell to accommodate floating head) pressure range – 75 psi to 600 psi.

Applications: Often used in refineries gas in shell units up to 600 psi high-pressure seal oil coolers up to 600 psi API 660 oil coolers.

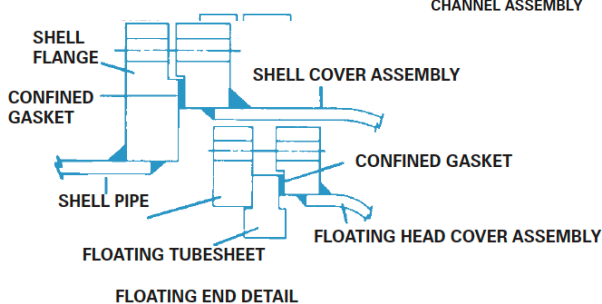
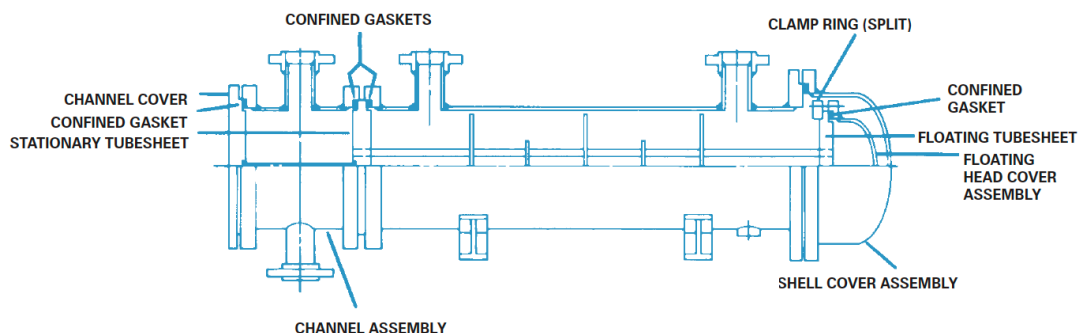

Advantages:

1. Higher efficiency compared to Type BET units because of smaller annulus and more tubes per shell size.
2. Tube bundle expands freely with no special provisions for expansion.

Limitations:

1. No gasket leak detection at floating head.
2. Floating head and fixed-end connection must be unbolted to remove tube bundle.

TEMA BEP Type 3

Description: Removable tube bundle, outside packed floating tubesheet design. Tubesheet assembly may be fabricated or forged steel to satisfy design pressure requirements tubeside fluid is fully gasketed; shellside packing available in various materials tubeside pressure range – to 3000 psi. Max 150 psi shellside.

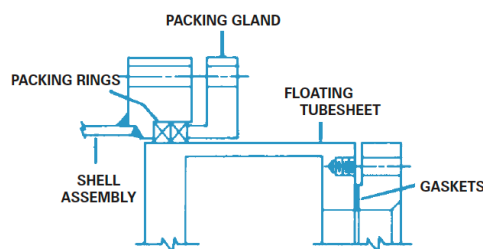
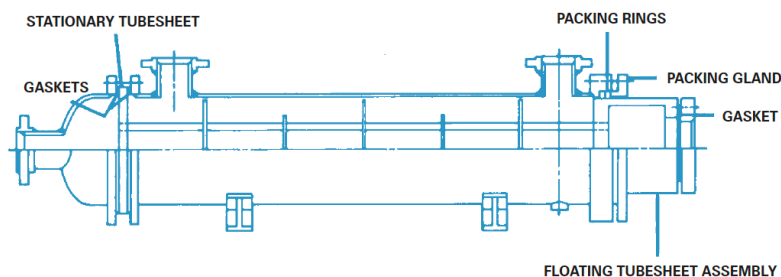

Applications: Where lethal or explosive gasses are involved where high pressure is applied only on the tubeside where gasket malfunction must be detectable.

Advantages:

1. No packing exposed to tubeside fluid.
2. Compared to BET and BES, outer tube limit (OTL) relatively close to shell ID resulting in increased heat transfer efficiency.
3. No possibility of shell & tubeside fluids intermixing through packing or gaskets.

Limitations:

1. One- or two- pass configurations only.
2. Shellside pressure up to 150 psi because of packing rings at floating tubesheet head.
3. Bundle expands into customer's piping.

TEMA BEM Type 5

Description: Fixed tubesheet, non-removable bundle tubesheet welded directly to shell single- or multi-pass design

Applications: Chemical processes high-pressure air and nitrogen chillers (gas in tubes, freon shellside).

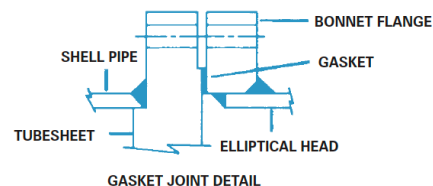
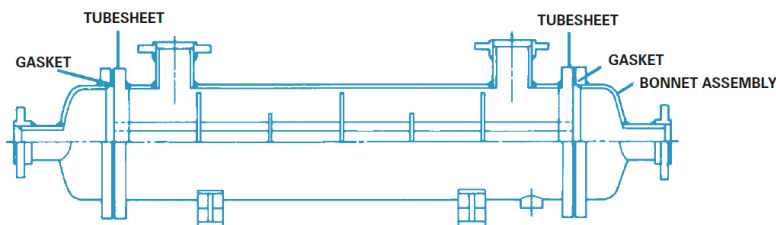

Advantages:

1. Economical design.
2. No possibility of contamination compared to designs with floating head gaskets (except in tube failures).
3. High-pressure shellside designs more easily accomplished than in floating-head types.
4. Extremely efficient shellside heat transfer due to small annulus between outer tube limit (OTL) and shell ID.
5. Shell design can be modified for large expansion area where partial vaporization of liquid occurs.
6. No gasketed joints on shellside.

Limitations:

1. No provisions for differential expansion of tubes and shell without expansion joint.
2. Shell and tubesheet material must be weldable.
3. Tube bundle is not removable for cleaning.

TEMA Shell & Tube Specifications

TEMA BEU Type 6

Description: U-tube design with pull through, removable or non-removable tube bundle furnished in multi-pass design only pressure range – 75 psi to 3000 psi tubeside and 75 psi to 1500 psi shellside.

Applications: Chemical processes tank suction heater liquid heaters vaporizers (where partial vaporization of liquid occurs).

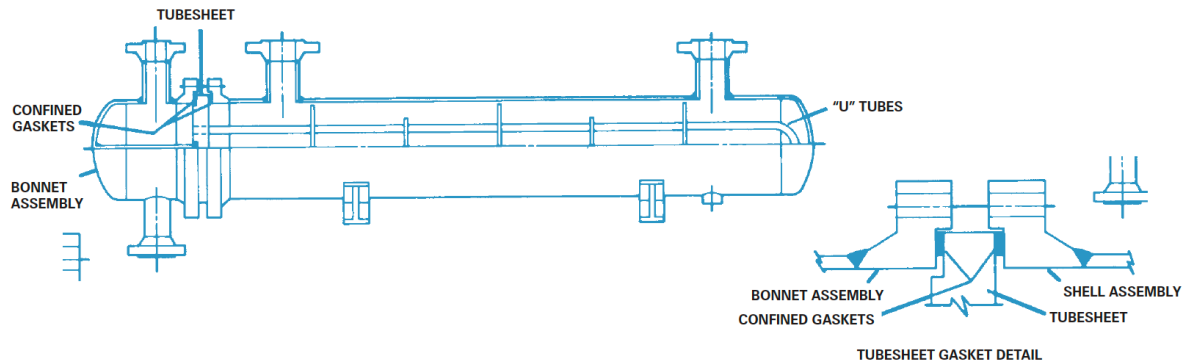

Advantages:

1. Tubes expand freely without special provisions.
2. Single tubesheet minimizes number of tubeside joints.
3. Economical construction.
4. Highly efficient heat transfer – small annulus between outer tube limit (OTL) and shell ID.
5. Tube bundle easily removable.

Limitations:

1. Outer tube rows must be removed before replacing inner rows.
2. Requires chemical cleaning.
3. May not be advisable for use where tubeside fouling is anticipated.

TEMA AEW Type 7

Description: Removable tube bundle, one- or two-pass design double-packed floating tubesheet with "O" rings and threaded retainer with telltale holes for leak detection shell sizes from 6" to 42" pressure range – 75 psi to 600 psi.

Applications: Lube oil coolers jacket water coolers aftercoolers.

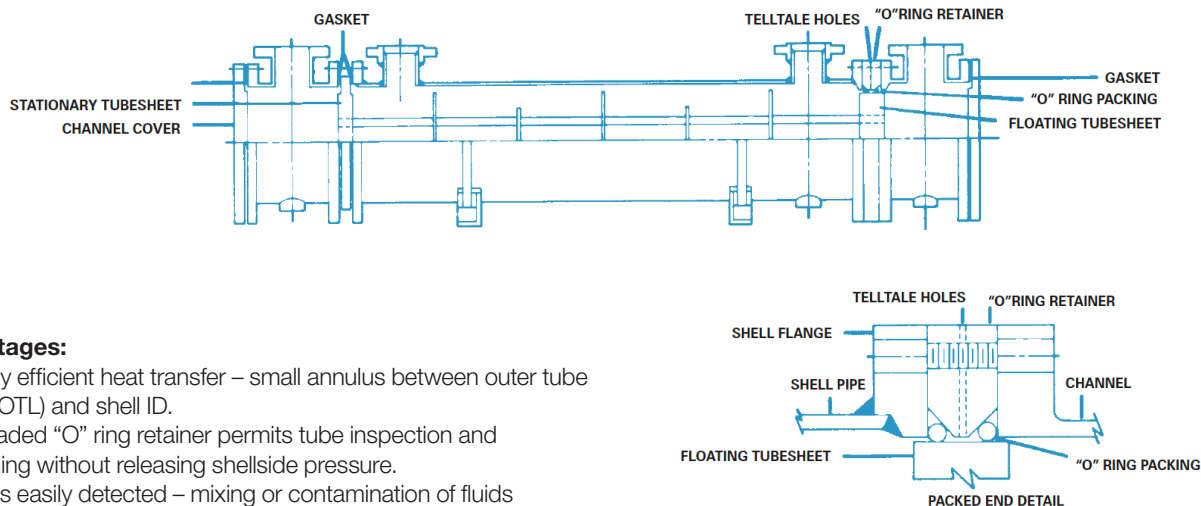

Advantages:

1. Highly efficient heat transfer – small annulus between outer tube limit (OTL) and shell ID.
2. Threaded "O" ring retainer permits tube inspection and cleaning without releasing shellside pressure.
3. Leaks easily detected – mixing or contamination of fluids eliminated.
4. Channel covers and return heads are easily removable for bundle inspection and cleaning.
5. Because of full thickness metal of "O" ring retainer, possibility of overtightening bolts and resultant "O" ring damage is eliminated.

Limitations:

1. Should not be used for explosive or lethal fluids where packing leak cannot be tolerated.
2. One- or two-pass configuration only.

Custom Designs

Description: Removable pull-through bundle, high-pressure closure, double shell, hairpin design Siller floating ring closure “O” ring packing, retainer and split ring seal shell and tubesheet assembly – permits bundle removal from reversing bonnet-end pressure range – 1200 psi to 6000 psi tubeside and 150 psi shellside.

Applications: High-pressure gas in the tubes.

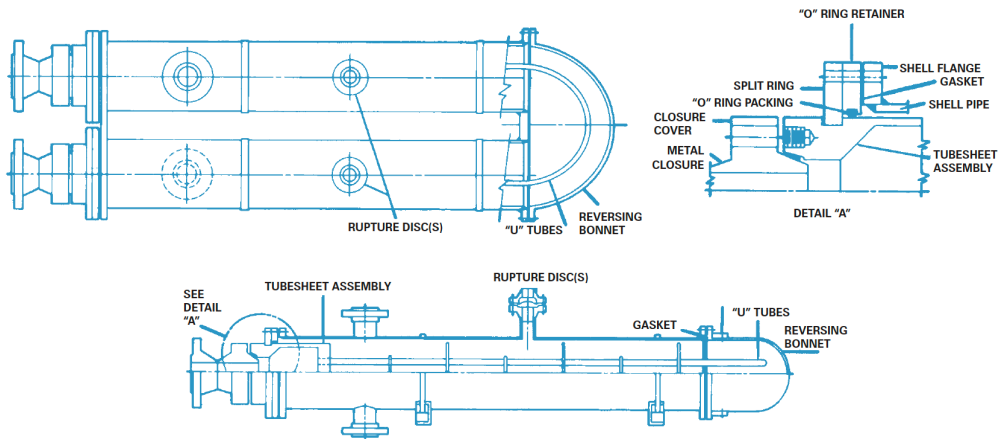

Advantages:

1. Replaces several “double-pipe” sections in high-pressure applications.
2. High heat transfer efficiency due to small annulus between outer tube limit (OTL) and shell ID.
3. Maximizes tube count and heat transfer service in given shell size.
4. Water and gas sealed off with two separate gaskets and two sets of bolts.
5. Desirable for applications that impose shell-length limitations.
6. Tube bundle easily removable for cleaning or inspection.

Limitations:

1. Outer tube rows must be removed before replacing inner rows.
2. Requires chemical cleaning.
3. May not be advisable for use where tubeside fouling is anticipated.

Description: Custom Basco high-pressure exchanger removable pull-through tube bundle, high-pressure closure, floating head, outside packed special Siller floating ring closure standard square neoprene packing used between floating tubesheet and shell flange.

Applications: High-pressure gas in the tube.

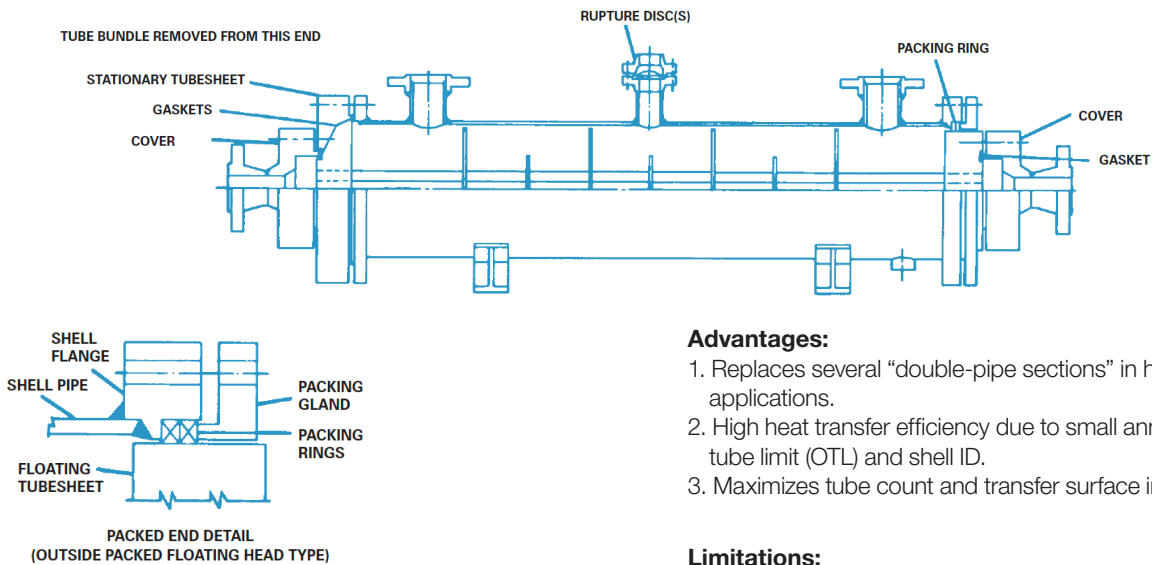

Advantages:

1. Replaces several “double-pipe sections” in high-pressure applications.
2. High heat transfer efficiency due to small annulus between outer tube limit (OTL) and shell ID.
3. Maximizes tube count and transfer surface in given shell size.

Limitations:

1. Single-pass configuration.



API Heat Transfer, a family of high-performance brands 

High-performance heat transfer.

It's who we are and what we do. It's part of our 140-year heritage designing and delivering world-class heat transfer products for nearly every industry. It's bolstered by our worldwide network of manufacturing facilities that provide sales, service, and support. And it's ingrained in a process that has helped customers around the world for nearly a century and a half.

When you work with us, you'll find the performance of our technologies sets the bar for heat transfer products, and our relentless drive to find and create custom heat transfer solutions to meet any industry challenge sets us apart.

See how our performance can improve yours.

Contact your API Heat Transfer sales rep or visit apiheattransfer.com today.

USA

Buffalo Facility

2777 Walden Avenue
Buffalo, NY 14225, USA
+1.716.684.6700

Iron Ridge Facility

1025 Industrial Road
Iron Ridge, WI 53035, USA
+1.920.387.4200

Franklin Facility

4700 Ironwood Drive
Franklin, WI 53132, USA
+1.414.761.4500

Racine Facility

5215 21st Street
Racine, WI 53406, USA
+1.262.554.8330

GERMANY

Bretten Facility

Langenmorgen 4
75015 Bretten, Germany
+49.7252.53.0

CHINA

Suzhou Facilities Building 1

156 Qingqiu Street, 3rd District
Suzhou Industrial Park
Suzhou, Jiangsu 215126, China
+86.512.8816.8000

Building 2

126 Qingqiu Street, 3rd District
Suzhou Industrial Park
Suzhou, Jiangsu 215126, China
+86.512.8816.8000

Shanghai

Meiheng Building
369 Wuzhong Road
Minhang District
Shanghai 201103, China
+86. 21.5426.2525

